

CATALOGUE N° 5



MICROPLAN GROUP

WWW.MICROPLAN-GROUP.COM

Workshop of Quarona



mpq@microplan-group.com



mpi@microplan-group.com

Workshop of Roccapietra



MICROPLAN ITALIA

Microplan Italia S.r.l.

13019 VARALLO (Vercelli) - Italy

Phone ++39-0163-54619

Fax ++39-0163-564081

Standard Articles & Electronic Devices
Special Workings on Drawing until 5m x 2 m

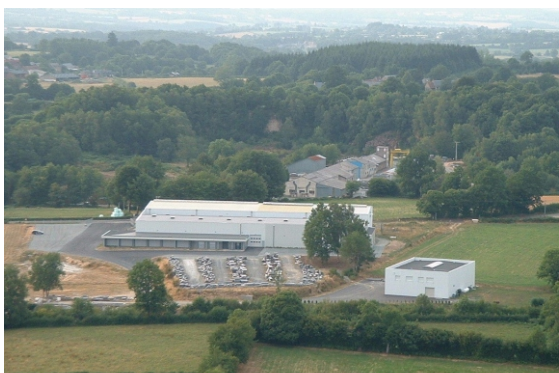

mpf@microplan-group.com



MICROPLAN FRANCE

Microplan France SA

F-23360 La Foret du Temple

Phone ++33-5-55.806666

Fax ++33-5-55806620

Standard Articles &
Special Workings on Drawing over 4m x 2m

CELITH

Celith Sarl

F-23360 La Foret du Temple

Phone ++33-5-55805454

Fax ++33-5-55805450

Synthetic Granite



celith@microplan-group.com



www.microplan-group.com

THE USE OF GRANITE IN METROLOGY



Due to its unique properties, black granite has in recent years been used extensively in the field of measuring instruments, both for traditional ones (surface plates, rules, set squares, etc...), as well as modern ones: three-dimensional measuring machines, physico-chemical process machine tools. Suitably lapped black granite surfaces are not only extremely precise but also ideal for use in conjunction with air bearings. The reason for the choice of black granite in constructing of precision units are the following:

- ✓ **DIMENSIONAL STABILITY:** black granite is a natural aged material formed over millions of years and therefore displays great internal stability.
- ✓ **THERMAL STABILITY:** the coefficient of linear expansion is much lower than for steel or cast iron.
- ✓ **HARDNESS:** comparable to good-quality tempered steel.
- ✓ **DURABILITY:** instruments last longer.
- ✓ **ACCURACY:** the regularity of the surfaces is superior to that obtained with traditional materials.
- ✓ **NON-ADHERENCE TO ACIDS, NON-MAGNETIC**
- ✓ **ELECTRICAL INSULATION**
- ✓ **RESISTANCE TO OXIDATION:** no corrosion, no maintenance.
- ✓ **COST:** with state-of-the-art technology prices are lower.
- ✓ **OVERHAUL:** Eventual servicing can be carried out quickly and cheaply.

For big plates of (over 5 meters), we usually use Blue Lanhelin, coming from Brittany, for the difficulties to find big blocks of Black Africa raw material.

SPECIAL WORKING ON GRANITE

To grant a complete service, Microplan usually makes special machining according to drawings, fields of working and needs of the Customer.

The main special granite workings are:

GLUING with epoxy of steel or stainless steel inserts and T-slots according to the hereunder table;

DRILLING: granite drilling for full or through holes (from $\phi 3$ to 300 mm);

MILLING with fitted diamond tools (in accordance with the limits of the metal milling).

TECHNICAL PROPERTIES OF MICROPLAN GROUP GRANITES

	AFRICA BLACK (Standard)	FINE BLACK (used on request)	BLUE LANHELIN (for big sizes)
DENSITY	2.85 kg/dm ³	3.0 kg/dm ³	2.7 kg/dm ³
POROSITY	0.09 %	0.15 %	0.35 %
COEFF. ELASTICITY	60 / 107 Gpa	80 / 103 Gpa	44 / 58 Gpa
COMPRESSION RESISTANCE	244 Mpa	270MPa	188 Mpa
RESISTANCE TO FLEXION	24 MPa	25 MPa	21.5 MPa
COEFF. LENGHT EXPANTION	6.5 x 10 ⁻⁶	5.9 x 10 ⁻⁶	7.4 x 10 ⁻⁶
HARDNESS SHORE	90	90	105
ORIGIN	SOUTHAFRICA	SOUTH AFRICA	FRANCE
COLOR	Dark Grey	Black	Blue-Grey

INSERTS APPLICATION DRAWING WITH SIZE TABLE AND T-SLOTS APPLICATION

SIZE TABLE FOR THREADED INSERTS

M	D	L	T (N)	S (Nm)
3	7,8	12	5125	2
4	9,8	16	6813	3
5	11,8	20	10204	6
6	12,8	27	14565	10
8	14,8	34	21023	25
10	17,8	42	31154	50
12	19,8	50	40966	85
14	21,8	60	53762	135
16	29,7	60	75455	200

M= Metrical Thread Iso 6H
 D= Insert diameter
 L= Insert length
 T= Unthreading resistance to traction after gluing with epoxy (resistance 12N/mm²)
 S= Maximum clamping torque

INSERT APPLICATION DRAWING

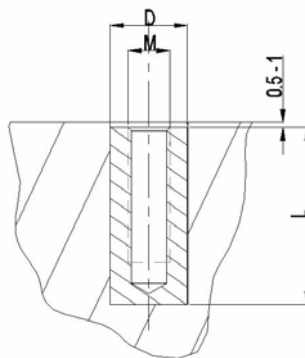

"T-SLOT" APPLICATION DRAWING

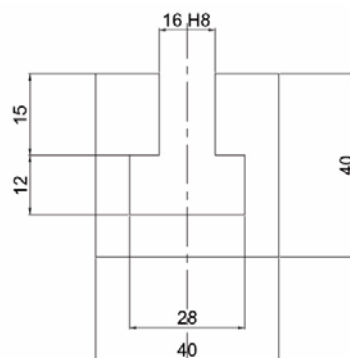

PN : BLACK GRANITE SURFACE PLATES

Black granite surface plates are manufactured in six accuracy grades according to standard ISO 8512-2, with the adding of high precision grade : "3", "2", "1", "0", "00" and "000" in order to satisfy all specific needs of the user, be it a workshop or a metrological office. All plates are tested with electronic levels or laser autocollimator in a temperature (20° C) and humidity controlled environment. All plates "Microplan" are supplied with a **test report** in which error map and installation instructions are related.

The table hereunder shows the standard sizes, the reference codes and the absolute flatness tolerances (in thousandths of mm). We can supply plates with different sizes according to the customer's needs and drawings with holes, glued threaded inserts, T-slots, clearing grooves and with rubber feet for the smaller sizes.

ATTENTION: For grade "00" and "000" thicknesses are higher!
The plates underscored in yellow meet the standard **ISO 8512-2**.

Packing: box / wooden pallet

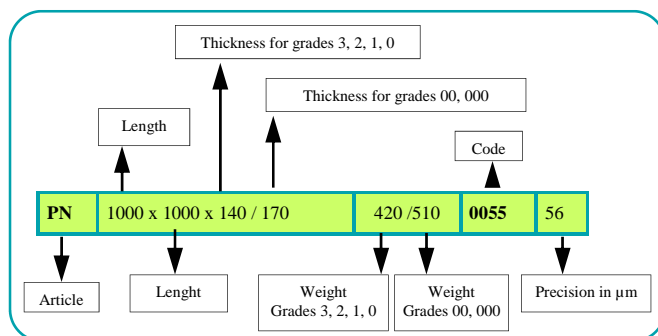

	SIZE in mm	Grade 3	Toll. µm	Grade 2	Toll. µm	Grade 1	Toll. µm	Grade 0	Toll. µm	Grade 00	Toll. µm	Grade 000	Toll. µm	Weight Kg
PN	300 x 200 x 40 / 50	0001	30	0002	15	0003	7	0004	3.5	0005	1.9	0006	1.3	8/9
PN	400 x 250 x 50 / 60	0007	32	0008	16	0009	8	0010	4	0011	2	0012	1,5	15/18
PN	400 x 400 x 60 / 70	0013	34	0014	17	0015	9	0016	4.5	0017	2.2	0018	1.6	29/37
PN	500 x 315 x 60 / 70	0019	34	0020	19	0021	9	0022	4.5	0023	2.2	0024	1.6	28/33
PN	500 x 500 x 80 / 90	0025	39	0026	20	0027	10	0028	5	0029	2.5	0030	1.8	60/68
PN	630 x 400 x 80 / 90	0031	39	0032	20	0033	10	0034	5	0035	2.5	0036	1.8	60/68
PN	630 x 630 x 90 / 100	0037	42	0038	21	0039	10	0040	5	0041	2.6	0042	1.9	107/119
PN	800 x 500 x 100 / 120	0043	44	0044	22	0045	11	0046	5.5	0047	2.8	0048	2	120/144
PN	1000 x 630 x 110 / 140	0049	49	0050	24	0051	12	0052	6	0053	3.1	0054	2.2	208/265
PN	1000 x 1000 x 140 / 170	0055	56	0056	28	0057	14	0058	7	0059	3.5	0060	2.5	420/510
PN	1200 x 800 x 140 / 170	0061	56	0062	28	0063	14	0064	7	0065	3.5	0066	2.5	403/490
PN	1600 x 1000 x 180 / 220	0067	66	0068	33	0069	16	0070	8	0071	4.1	0072	2.9	864/1056
PN	2000 x 1000 x 210 / 260	0073	75	0074	38	0075	19	0076	9.5	0077	4.7	0078	3.3	1260/1560
PN	2000 x 1500 x 230 / 280	0079	80	0080	40	0081	20	0082	10	0083	5	0084	3.5	2070/2520
PN	2500 x 1600 x 280 / 340	0085	92	0086	46	0087	23	0088	11.5	0089	5.8	0090	4	3360/4080

DH / DP: "DHARLA" SERIE - GRANITE SURFACE PLATES -

CODE	SIZE in mm	Precision Grade	Precision in µm	NET WEIGHT
DH500	500 X 315 X 70	DIN 876/0	6.00	33 KG
DH630	630 X 400 X 80	DIN 876/0	6.52	60 KG
DH800	800 X 500 X 100	DIN 876/0	7.20	120 KG
DH1000	1000 X 630 X 140	DIN 876/0	8.00	260 KG
DH1200	1200 X 800 X 160	DIN 876/0	8.80	460 KG
DH1600	1600 X 1000 X 180	DIN 876/0	10.40	860 KG
CODE	SIZE in mm	Precision Grade	Precision in µm	NET WEIGHT
DP500	500 X 315 X 70	DIN 876/00	3.00	33 KG
DP630	630 X 400 X 80	DIN 876/00	3.26	60 KG
DP800	800 X 500 X 100	DIN 876/00	3.60	120 KG
DP1000	1000 X 630 X 140	DIN 876/00	4.00	260 KG
DP1200	1200 X 800 X 160	DIN 876/00	4.40	460 KG
DP1600	1600 X 1000 X 180	DIN 876/00	5.20	860 KG



The granite plates of the Economic serie "Dharla", are supplied in two grades of precision according to the standard **DIN 876/0 e DIN 876/00**. All plates come supply with **Test Report** with flatness graphic representation.

- ✓ Polished sides
- ✓ 45° Corners
- ✓ Engraved Serial Number

Packing: wooden box



PA : LIGHTENED GRANITE SURFACE PLATES

The alveolar inside structure made of glued granite cross-bar considerably reduces the weight of the granite surface plate. The advantages in respect of the solid granite plate are the following: reduction from 40% to 60% of the weight; quick settling in temperature of the plate; less inside tensions and better stability of the granite self; lightening simplifies its handling; **reduction of the freight costs.**

The second value of **thickness** indicated in the column "Size" is for grade "00".

Packing: wooden pallet

	SIZE mm	Grade 1	µm	Grade 0	µm	Grade 00	µm	KG
PA	2000 x 1000 x 230 / 260	0100	19	0101	9.5	0102	4.7	548 / 576
PA	2000 x 1500 x 250 / 280	0103	20	0104	10	0105	5	802 / 836
PA	2500 x 1000 x 270 / 300	0106	22	0107	11	0108	5.5	793 / 828
PA	2500 x 1500 x 300 / 330	0109	23	0110	11.5	0111	5.8	1170 / 1213
PA	3000 x 1000 x 320 / 360	0112	24	0113	12	0114	6	1145 / 1197
PA	3000 x 1500 x 340 / 380	0115	25	0116	12.5	0117	6.4	1840 / 1932
PA	3000 x 2000 x 370 / 410	0118	27	0119	13.5	0120	6.8	2610 / 2743
PA	3500 x 1000 x 370 / 410	0121	27	0122	13.5	0123	6.8	1768 / 1883
PA	3500 x 1500 x 390 / 430	0124	28	0125	14	0126	7.1	2554 / 2699
PA	3500 x 2000 x 410 / 460	0127	30	0128	15	0129	7.4	3851 / 4102
PA	4000 x 1500 x 430 / 480	0130	31	0131	15.5	0132	7.7	3248 / 3441
PA	4000 x 2000 x 450 / 500	0133	32	0134	16	0135	8	4493 / 4759

RL: BLACK GRANITE LINEAR RULES

	SIZE mm	Kg	Grade 1	□ µm	Grade 0	□ µm	Grade 00	□ µm
RL	300 X 30 X 50	1,3	0150	6,4	0151	3,2	0152	2,6
RL	400 X 40 X 60	2,2	0153	7,2	0154	3,6	0155	2,8
RL	500 X 50 X 80	5	0156	8	0157	4	0158	3
RL	630 X 50 X 80	7	0159	9	0160	4,4	0161	3,2
RL	800 X 50 X 100	10,5	0162	10,4	0163	5,2	0164	3,6
RL	1000 X 60 X 120	15	0165	12	0166	6	0167	4
RL	1400 X 60 X 150	35	0168	15,2	0169	7,6	0170	4,8
RL	1600 X 80 X 180	53	0171	16,8	0172	8,4	0173	5,2
RL	2000 X 80 X 200	89	0174	20	0175	10	0176	6

For high precision testing of linearity, for comparing guides or lapped surfaces. Their shape has been studied to give maximum stability. The lapping on one face is carried out to three levels of precision with tolerances as shown beneath. They can be supplied with handles on the heads.

Packing: box / wooden case



RP: BLACK GRANITE LEVEL PARALLEL RULES

Manufactured with two H-shaped lapped parallel surfaces to ensure stability and lightness. The three levels of tolerances are shown in the table. The parallelism tolerance is equal to the flatness. If required, they can be supplied with handles on the heads.

Packing: box / wooden case



	SIZE mm	Kg	Grade 1	□ // µm	Grade 0	□ // µm	Grade 00	□ // µm
RP	500 X 50 X 80	5	0180	8	0181	4	0182	3
RP	750 X 50 X 100	10	0183	10	0184	5	0185	3,4
RP	1000 X 60 X 140	23	0186	12	0187	6	0188	4
RP	1500 X 80 X 180	40	0189	16	0190	8	0191	5
RP	2000 X 100 X 220	80	0192	20	0193	10	0194	6

SQ: BLACK GRANITE SQUARES



	SIZE mm	Grade	□ µm	⊥ µm	KG	
SQ	0196	300 x 200 x 40	Workshop	6.4	7.8	4.7
SQ	0197	400 x 250 x 50	Workshop	7.2	8.4	10
SQ	0198	500 x 315 x 60	Workshop	8	9	17
SQ	0199	630 x 400 x 60	Workshop	9	9.6	28



	SIZE mm	Grade	□ µm	⊥ µm	KG	
SQ	0200	200 X 150 X 30	Laboratory	2.4	2	1,8
SQ	0201	300 X 200 X 40	Laboratory	2.6	2	4,7
SQ	0202	400 X 250 X 50	Laboratory	2.8	2	10
SQ	0203	500 X 315 X 60	Laboratory	3	3	17
SQ	0204	630 X 400 X 60	Laboratory	3.2	3	28
SQ	0205	800 X 500 X 80	Laboratory	3.6	4	63
SQ	0206	1000 X 630 X 100	Laboratory	4	4	117
SQ	0207	1200 X 800 X 140	Laboratory	4.4	5	210
SQ	0208	1500 X 1000 X 160	Laboratory	6	6	480

Perfect for squareness testing, set squares are extremely reliable due to their exceptionally limited tolerances and the stability of the base.

Holes are made in larger versions to **reduce weight** and facilitate the transport.

The tolerance of the lateral faces is $\pm 20 \mu\text{m/m}$. Supplied in two grades of precision, for **Laboratory and Workshop** use.

Original Test Report with Primary Instruments Reference included.

Packing: box / wooden pallet

CL : ADJUSTABLE COLUMNS FOR SURFACE PLATES

Made from a highly resistant compressed cement agglomerate inside an ABS sheath.
Adjusting screws Ø M30 x 2 with a nut lock and an oscillating plate on a ball (polished steel).

SUGGESTED COLUMNS NUMBER

Nr. 3/5 for plates 1200x800
Nr. 5 for plates until 2000x1000
Nr. 7 for plates 2000x1500
Nr. 9 for plates 2500x1500
Nr.11 for plates 3000x2000
Nr.13 for plates 4000x2000

		SIZE	ø Base	KG
CL	0252	Adjustable High 380/480 mm	mm 220	28
CL	0255	Adjustable High 480/580 mm	mm 200	25
CL	0256	Adjustable High 680/780 mm	mm 220	30

Color Black or RAL5021; Packing: pallet



TN : SUPPORT FOR SURFACE PLATES - TABLE TYPE

Constructed with welded and laminated steel sections with 5 adjusting screws and 4 vibration dampers feet.

Painting color: Ral 5021.

Packing: plastic film / at sight

		Support for plate size	KG
TN	0260	630 X 400 mm	25
TN	0261	630 X 630 mm	29
TN	0262	800 X 500 mm	30
TN	0263	1000 X 630 mm	35
TN	0264	1000 X 1000 mm	38
TN	0265	1200 X 800 mm	38
TN	0266	1600 X 1000 mm	44
TN	0267	2000 X 1000 mm	48



TC : SUPPORT FOR SURFACE PLATES - TABLE TYPE WITH DRAWERS

Like the previous model but with locking drawers 500x500 mm in sheet-steel and lock. Until 1000x1000 mm, with one drawer. Beyond 1200x800 mm, with two drawers. With 5 adjusting screws and 4 vibration dampers feet.

Painting color: Ral 5021.

Packing: plastic film / at sight

		Support for plate size	KG	Number of Drawers
TC	0270	630 X 630 mm	34	1
TC	0271	800 X 500 mm	35	1
TC	0272	1000 X 630 mm	40	1
TC	0273	1000 X 1000 mm	43	1
TC	0274	1200 X 800 mm	48	2
TC	0275	1600 X 1000 mm	54	2
TC	0276	2000 X 1000 mm	58	2
TC	0277	Single Drawer	5	-



TA : SUPPORT FOR PLATES - CUPBOARD TYPE

Built with welded steel with walls of sheet iron with two doors and one shelf inside. With 5 adjusting screws and 4 vibration dampers feet.

Painting color: Ral 5021.

Packing: plastic film / at sight

		Support for plate size	KG
TA	0285	1000 X 630 mm	60
TA	0286	1000 X 1000 mm	70
TA	0287	1200 X 800 mm	70
TA	0288	1600 X 1000 mm	100
TA	0289	2000 X 1000 mm	130



“DHARLA” SERIE - SUPPORT FOR PLATES

Welded Steel Support of the economy serie “Dharla”. Completed of adjustment screws..

Without vibration dampers.

Painting color: Ral 4008 (violet)

Packing: plastic film / at sight

COD.	Support for plate size	Net Weight
DS 630	630 X 400 mm	25 KG
DS 800	800 X 500 mm	28 KG
DS 1000	1000 X 630 mm	30 KG
DS 1200	1200 X 800 mm	35 KG
DS 1600	1600 X 1000 mm	40 KG



VR: ADJUSTABLE FEET

Support and adjustment feet are made of burnished steel, with threaded bases, sphere head screws and oscillating plates.

Supplied in three sizes as in the table hereunder:

Packing: box

VR	Ø Screw	Ø EXT.	H min	H max
0253	M30 X 1.0	55	68 mm	88 mm
0254	M40 X 1.5	65	68 mm	98 mm
0257	M60 X 1.5	100	94 mm	110 mm



BC: CONCENTRICITY TEST BENCH

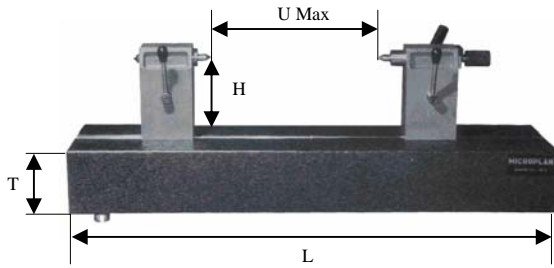

(U Max = Useful distance between point)

Composed by a pair of cross-points (CP) and a black granite base of a reduced width, lapped at grade 1 and a central T-slot mm 16H8; 3 adjustable feet.

Packing: wooden pallet

		U Max.	H	L	W	T	KG.
BC	0140	300 mm	150 mm	700 mm	250 mm	100 mm	76
BC	0141	600 mm	150 mm	1000 mm	300 mm	140 mm	149
BC	0142	1100 mm	150 mm	1500 mm	350 mm	180 mm	307
BC	0143	1600 mm	200 mm	2000 mm	400 mm	220 mm	556
BC	0144	2100 mm	200 mm	2500 mm	500 mm	250 mm	928

CP: CROSSPOINTS

		Description	KG
CP	0385	CROSSPOINT PAIR - High 150 mm	23
CP	0386	CROSSPOINT PAIR - High 200 mm	28
CP	0387	CROSSPOINT PAIR - High 250 mm	42

MEEHANITE WA structure standardised anti-wear. Steel tube in cemented Ni-Cr. Points with attachment CM 2. Parallelism between the axis point and the base 0,01 mm. Point alignment $\pm 0,01$ mm. Overall dimension: 350 mm. Key 16 mm.

Packing: box / wooden pallet



CI: BLACK GRANITE CYLINDERS



The black granite cylinders are manufactured with two support surfaces which are perpendicular to the cylindrical surface. Suitable for squareness test, cylinders have reduced tolerances both on generatrix straightness as well as on cylindricality.

Packing: box / wooden pallet

		Ø mm	H mm	⊥	Cylindricity	KG
CI	0390	70	200	2 μ m	2 μ m	2
CI	0391	80	300	3 μ m	3 μ m	4
CI	0392	100	400	4 μ m	4 μ m	8
CI	0393	120	500	5 μ m	5 μ m	12

CU: BLACK GRANITE CUBES

Manufactured with either two, four or six lapped, plane and parallel surfaces. See table for dimensions and tolerances. With threaded holes on all faces on request.

Packing: box / wooden pallet

	Size	∇ μ m	// μ m	⊥ μ m	2 Faces	4 Faces	6 Faces	KG
CU	Lato 50 mm	1,5	2		0225	0226	0227	0,4
CU	Lato 100 mm	2	2		0228	0229	0230	3
CU	Lato 150 mm	2,4	3		0231	0232	0233	10
CU	Lato 200 mm	2,8	3		0234	0235	0236	24



PR: PAIR OF GRANITE "V" PRISMS 90°

		Size in mm	∇ μ m	// μ m	KG	Ø Max
PR	0240	100 X 70 X 50	2	4	1	100 mm
PR	0241	140 X 100 X 60	2	4	2	140 mm
PR	0242	200 X 140 X 70	3	6	6	200 mm

Ideal for testing cylinders. The tolerances in the table (in thousandths of a millimetres) refer to the flatness of the base and the parallelism between the base and the axis of the V-shaped groove. On request, other faces can be lapped.

Packing: box



PL: BLACK GRANITE PARALLELEPIPED

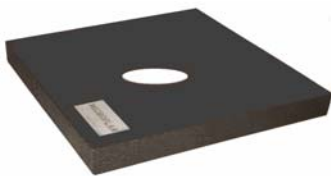

		Size in mm	∇ μ m	⊥ μ m	KG
PL	0243	500 x 250 x 50	3	2	14
PL	0244	750 x 350 x 60	4	3	36
PL	0245	250 X 250 X 40	2	1,5	7
PL	0246	350 X 350 X 50	2	1,5	18
PL	0247	500 X 500 X 50	3	2	30
PL	0248	750 X 750 X 60	4	3	70
PL	0249	1000 X 1000 X 80	4	4	150
PL	0250	1000 X 500 X 80	4	4	70

Its square form ensures greater stability with respect to the set squares while the use of the third side allows a surer testing of the angle error. Three faces lapped perpendicular each other and the upper base. Three adjustable feet are fitted to the lateral face. It is provided with a hole for lightening in the middle. It is suitable for the squaring tests upon measuring instruments and machine tools.

Packing : wooden pallet

TZ / DT: CLEANING AND MAINTENANCE PRODUCTS FOR GRANITE INSTRUMENTS

TZ0510: CLEANING AND MAINTENANCE PASTE FOR GRANITE INSTRUMENTS

Specific product for the cleaning and maintenance of granite instruments. Its special formula avoids any cause of friction and wear, and it assures an improvement in the sliding of fittings on the granite and a perfect cleaning. A small quantity is enough to properly prepare granite surfaces. It is supplied in a box of 300 cc with a threaded cap.

Minimum order: 3 boxes.

DT0520: LIQUIDE DETERGENT FOR GRANITE

Liquid detergent for daily cleaning of granite instruments. With spray, 1 litre.

Minimum order: 5 boxes.

Imballo: box / wooden pallet



PT : PERTEST – SQUARENESS TEST INSTRUMENT WITH DIRECT ERROR

The perpendicularity test instrument (PERTEST) allows practically, quickly and directly to survey perpendicularity and straightness errors with the lowest tolerance. No tare, squares or cubes are required. Peritest is always ready to be used since the structure in granite and the working precision assure stability and repetition. The sliding of the gauge (not supplied) stand is on air bearings as for the transference onto the base in order to avoid all friction and wear causes. The gauge is moved up and down by pushing bottom; moreover Peritest is provided with filtering and regulation unit for the compressed air.

Packing: box / wooden pallet

PT	0325	0326	0327	0328	0329
HIGHT	500 mm	685 mm	935 mm	1185 mm	1685 mm
WIDTH	250 mm	250 mm	300 mm	350 mm	450 mm
THICKNESS	140 mm	140 mm	140 mm	160 mm	180 mm
RUN	250 mm	500 mm	750 mm	1000 mm	1500 mm
ANGLE ERROR Max.	1"	1"	1"	1"	1"
STRAIGHTNESS (mm)	0,001	0,002	0,003	0,004	0,005
RIPEATABILITY (mm)	0,001	0,001	0,001	0,001	0,001
PRESSURE - BAR	4,5	4,5	4,5	4,5	4,5
WEIGHT kg	22	45	60	100	180



ROCKO : SQUARENESS TEST INSTRUMENT

Squareness test instrument through gauge (not supplied) composed by:

- * **Structure in black granite** with the support surface and vertical sliding faces lapped
- * **Sliding cart** on air bearing with stiffening obtained by a Venturi empty generator.
- * **Little cart** for the pneumatic moving of the vertical run sliding.

The vacuum-pneumatic vertical cart is moved by a valve which works on the pneumatic piston linked to the cart by a wire. Turning the valve, the cart will move into two directions, up and down, with progressive speed. The pneumatic movement avoids the direct contact of the cart by the operator, in order to guarantee the best repeatability and stability.

Packing: wooden pallet



TECHNICAL PROPERTIES	
Hight	466 mm
Width	140 mm
Thickness	240 mm
Run	300 mm
Angle error	1"
Linearity	0,001 mm
Repeatability	0,001 mm
Pressure	3,5 Bar
Weight	Kg. 29

TR: ROTATING TABLE ON AIR BEARINGS

The rotating table is composed of two granite disks moving on a **pressure/vacuum air bearing** in a way to obtain the maximum rigidity even changing loads for testing. The bottom disk can translate on the base while the upper disk rotates round the vertical axis, all thanks to the air bearing system. The instrument is supplied with a **compressed-air filtering/regulation unit** and controlling device. **Other sizes on request.**

Packing: wooden pallet

TECHNICAL PROPERTIES	TR0475	TR0477	TR0478
Ø Disc	295	395	495
Weight (Kg)	36	62	106
Pressure	4,5	4,5	4,5
Rotation axis precision	1 µm	1 µm	1 µm
Horizontal disc precision	2 µm	2,5 µm	3 µm
Maximum load	60	100	170



TR 0476 : ADJUSTMENT SYSTEM

It is an accessory for the rotating table; it allows to centre on the vertical axis the rotating piece; using a self-centring chuck to fix the piece, it's possible to adjust the perpendicularity of the vertical axis, simply working on the three level regulations at 120° and the two at 90° to move the axis of the piece compared to the rotation axe. Made in treated steel for hardness it is fixed on the rotating table through the threaded inserts.

(In the picture: Rotating table with adjustment system and self-centring chuck *not included in the supply*)

AB: AIR BEARINGS

In recent years air bearings have been used in several fields: for measuring machines, machine tools, control benches, optical-electronic applications, etc. Due to their particular properties they have reached a large diffusion: precision, extremely low friction, good rigidity, endless time length, vibration-proof, the possibility of moving considerable weights using minimum power. Moreover we can obtain excellent results by applying air bearings to the granite guides and then reaching linearity precision of about 1.m/mt. In order to facilitate the project of machines, air bearings are manufactured in standard sizes and circular shapes to obtain their peak efficiency (we can supply right-angled shaped too, but their efficiency shrinks in relation to the area). This article is made from an aluminium alloy that has been anodised for strength. The sliding area is lapped. We produce two versions of air bearings:

AB 0480/0486 ADJUSTABLE AIR BEARINGS: fitted and adjusted with thin screws which operate on a steel ball located in the proper seat.

AB 0487/0493 : CONTRAST AIR BEARINGS: they have to be fitted inside proper seats generally obtained from the cart itself in a way to exercise a regular thrust on the bearing through compressed - feedings of air. They usually have to be placed together with the adjustable bearings.

Packing: box / pallet

ADJUSTABLE AIR BEARINGS

AB	K (N) 4,5 BAR	Diameter mm	Thickness mm	Air Aliment.	Ball ø mm	Ø Adjust. screw	Weight Kg
0480	170	30	14	Ø M5	7,8	M12X1,25	0.03
0481	350	40	16	Ø M5	7,8	M12X1,25	0.06
0482	590	50	20	Ø M5	7,8	M12X1,25	0.12
0483	790	60	24	Ø M5	12,7	M16X1,5	0.20
0484	962	70	28	Ø M5	12,7	M16X1,5	0.32
0485	1300	80	32	Ø M5	12,7	M16X1,5	0.48
0486	2000	100	40	Ø M5	15,8	M20X1,5	0.94

CONTRAST AIR BEARINGS

AB	K (N) 4,5 BAR	Diameter mm	Thickness mm
0490	170	30	12
0491	350	40	14
0492	590	50	18
0493	790	60	20
0494	962	70	23
0495	1300	80	27
0496	2000	100	31



PC 0315: LINO – GAUGE STAND SUPPORT WITH VACUUM /PNEUMATIC BASE

Device composed by an angle base made in aluminium strength anodise alloy. Each unit consists of an air bearing, fixed to the sliding surface plate through a pneumatic vacuum action. On the base is located a nimble arm for gauge stand with 8H7 hole for standard gauges suitable. It is possible to assemble the two elements of the base for a guided length side sliding or use the upper unit only for the free sliding onto the surface plate. You can independently switch on and off pressure and depression by acting on the four valves. Provided with pneumatic station, the stand support is extensively used on granite surface plates with one or more lapped faces. Adjustable "L"-base according to different sliding sides.



(FEEDING DEVICE: COMPRESSED AIR 4 BAR / CONSUMPTION 30 l/min).

Packing: box

PC: GAUGE STAND SUPPORTS

PC0318 THREADED COLUMN FOR GAUGE STAND SUPPORT



Adjustable arm set with threaded column composed of: stainless steel threaded column Ø 35 mm H330 mm, nut for vertical movement, stainless steel arm Ø 20 mm, cursor with separate screw stops for column and arm, fine adjustment, gauge attachment Ø mm 8H7, screws for attachment to the base (PC 0319 or 0320)

Packing: box

PC0317 SMOOTH COLUMN FOR GAUGE STAND SUPPORT



Adjustable arm set composed of stainless steel column Ø 20 mm H 220 mm, stainless steel arm Ø 16 mm, cursor with separate screw stops for arm and column, fine adjustment, gauge attachment Ø mm 8H7, screw for attachment to base. (PC 0319 or PC 0320)

Packing: box

PC0319 BASE FOR A GAUGE STAND 250 X 160 X 40 mm Grade 1

Granite base for gauge stand 250 x 160 x 40: upper face lapped grade 1 with hole for column and rubber feet.

PC0320 BASE FOR A GAUGE STAND 300 X 200 X 50 mm Grade 1

Base for gauge stand 300 x 200 x 50 mm lapped grade 1 on the upper face with hole for a column and rubber feet.

Packing: box

PC0322 GAUGE STAND SUPPORT WITH MICROMETRIC ADJUSTMENT



Black granite base mm 300 X 200 X 50 lapped grade 0, with column ø 35X300 mm, aluminium slider. Micrometric adjustment.

Packing: box

HV: HORIZONTAL & VERTICAL CONCENTRICITY TEST BENCH

Composed by a black granite single block shaped to lodge two stainless steel points aligned with the "V"; the "V" axis is parallel to the base. You can place the bench in horizontal position through the handle fixed on one head, perpendicular to the axes of the points.

On request, other sizes are supplied.

Packing: box / wooden pallet

SIZE	400 x 200 x 160 mm
DISTANCE BETWEEN THE POINTS	50 : 200 mm
POINTS SUPPLIED	Nr. 1 mm 80 x ø 30 + Nr. 2 mm 150 x ø 30
FACES FLATNESS TOLERANCE	∇ 0.004 mm
PERPENDICULARITY TOLERANCE	⊥ 0.004 mm
BASE / POINTS AXIS TOLERANCE	// 0.005 mm
WEIGHT	KG. 28



BB: CONCENTRICITY TEST BENCH WITH SINE BAR

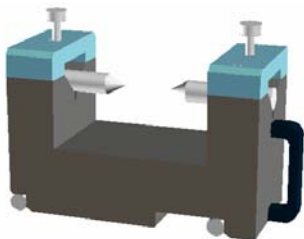

Similar to the "HV Bench" for the upper side, then with the seats for the sine bar lodgement, placed at 300 mm. For the testing of taped elements, by using little test blocks. You get some angles between the base and the axis of the points. (On request, other sizes are supplied).

Per dimensioni diverse richiedere offerta.

Packing: box / wooden pallet

SIZE	400 x 200 x 160 mm
DISTANCE BETWEEN THE POINTS	50 : 200 mm
SINE BAR ROLLERS DISTANCE TOL.	300 mm ±0.004
POINTS SUPPLIED	Nr. 1 mm 80 x ø 30 + Nr. 2 mm 150 x ø 30
FACES FLATNESS TOLERANCE	∇ 0.004 mm
PERPENDICULARITY TOLERANCE	⊥ 0.004 mm
BASE / POINTS AXIS TOLERANCE	// 0.005 mm
WEIGHT	KG. 27

AF 0600: "WILMA" DISPOSITIVO LASER PER CONTROLLI DI LINEARITA'

Electronic device with laser for straightness testing with steel wire "Wilma" is an electronic device studied for straightness testing, for example of machine tools, on which it is placed, respect to a wire fixed with two supports at the extremities. The eventual error is showed through a led display on the top of the instrument, while a digital micrometric table with thousand read gives the exact data. The device can stock until 200 measures in a inner memory : then, is possible to transfer all the found data to the PC through the RS-232 interface. An electronic sheet will be automatically generated with a graphic of the straightness.

Wilma is powered by rechargeable batteries and comes supplied with battery charger (220 V - 50 Hz), one coil of harmonic steel wire, user's guide and CD-R with "Wilma" Software.

Packing : box



Resolution: 0.001 mm
Precision: ± 0.005
 Electronics based on microprocessor
Auto-calibration on each switch on Solid State Laser optic - visible field- Class II
 Vertical Adjustment
 Optical rule gauge
Temperature of use: 15° / 25° C
Wire diameter: 0.3 mm
Wire length: ca. 900 m (500 gr.)
Allowed wire deviation: 35 mm
Powering: NI-MH Rechargeable batteries
Recharging time: 16 ore ca.
Autonomy: about 10 hours
 Self extinction when the battery is exhausted
Display: bicolour led panel + LCD Display
RS-232 Interface for PC connection
Weight: 5,1 Kg

ELECTRONIC LEVELS

The electronic level is a high-precision instrument for testing the inclination and the slope relative to the horizontal or any given angle. The reading is expressed in seconds of the arc by way of a numeric display allowing a rapid readout. The instrument works on a pendulum principle. A pendulum always hangs vertically thus allowing measurement of the variance relative to the horizontal base. For all levels, the mechanic is putted in a oil-bath metallic box with high shock protection. The electronic level is currently employed in the following applications:

- ☞ Error detection of linearity, planarity and parallelism;
- ☞ Mounting and levelling of machinery;
- ☞ Testing of inclination, slant and flexion in civil engineering.



LE 101: ANALOGUE ELECTRONIC LEVEL

The electronic level is composed of the LE 101 sensing unit and the VA 110 readout unit. Data is transmitted from the sensor to the display by cable. Using this configuration the user can read the inclination values on the display even if the sensor is in an awkward position. A switch allows to select one of the 3 measuring scales. It is possible to connect two LE 101 sensing units to the VA 110 display unit for readings to be collected from different sources. This is particularly useful where floors are not perfectly stable. Rechargeable battery-powered, has a warning indicator of insufficient charge. It comes supplied in ABS box with user's guide.

Packing: box

- Resolution: On request "High Sensibility"	Range A : 250 $\mu\text{m/m}$ for division / Range B : 50 $\mu\text{m/m}$ for division / Range C : 5 $\mu\text{m/m}$ for division	
- Field of Measure: On request "High Sensibility"	Range A : 25 $\mu\text{m/m}$ for division / Range B : 5 $\mu\text{m/m}$ for division / Range C : 1 $\mu\text{m/m}$ for division	
- Reaction Time:	Range A : 5000 $\mu\text{m/m}$ / Range B : 1000 $\mu\text{m/m}$ / Range C : 100 $\mu\text{m/m}$	
- Straightness:	Range A : 500 $\mu\text{m/m}$ / Range B : 100 $\mu\text{m/m}$ / Range C : 20 $\mu\text{m/m}$	
- Powering :	3 sec tipico	- Zero Setting: $\pm 1500 \mu\text{m/m}$
	$\pm 2\%$	- Reference temperature: 20°C - 50% U.R.
- Level Weight :	Rechargeable battery	- Autonomy: 20 h - normal use,
- Read-out Unit :	with Low Battery testing bottom	15 h - differential mode
- Input:	Base 100: 1,1 Kg Base 200: 1,7 Kg Square Base: 3,9 Kg	about 15 h
- Powering :	1 Kg	Level LE 101 mm 100x50x87 + base
- RS232 Interface (optional) for data transmission to PC	2 external differentiable	Read-Out VA 110 mm 205x160x115
	220 V a.c. 20 mA.	Cable Length : 3 m

LE 201: DIGITAL ELECTRONIC LEVEL

The new "LE 201" electronic level, replaces the old model, while improving its performance and ease of use. It is a high precision instrument for very small angle measurement, with the following specifications:

- ▲ MICROPROCESSOR-BASED LOGIC
- ▲ LINEARITY AND FLATNESS MEASURES
- ▲ FACTORY-SELECTABLE MEASURE UNIT: $\mu\text{m/m}$, sec, mrad
- ▲ ONLY THREE KEYS KEYBOARD: UP, DOWN E ON/OFF
- ▲ OPTIONAL WINDOWS SOFTWARE FOR DATA PROCESSING
- ▲ DIFFERENTIAL MODE CAPABILITY (with "LE 301" level)

This electronic system is based on a high performance microprocessor. The microprocessor is in charge of every operation within the instrument, going from the position transducer (a very sensitive LVDT- Linear Variable Differential Transformer), to the analogue-to-digital converter, to the system calculations and data display. Measures are continuously taken and processed, to average out electronic noise and high-frequency mechanical vibrations. Sensitivity is as high as 0.5 $\mu\text{m/m}$ (0.1 second of arc). The internal software manages the whole acquisition process, the measures averaging and the data display on a 16-characters LCD. By means of two keys on the front panel, the measuring reference can be moved up and down, to set the zero and simplify the process. The level may be complemented by a Windows application, especially designed for an easy and straightforward data processing, archiving and printing, as well as graphic rendering of the surface or line under test. This makes it possible to produce a complete and accurate information of the measured surfaces. Supplied in ABS box with user's guide.

Packing: box



Resolution: 0.1 sec/1 μrad / 0.0005 mm/m
Field of Measure: 655 sec
Reaction Time: 3 sec tipic
Straightness: $\pm 2\%$
Ref. temperature: 20°C - 50% H.R.
Alimentation : rechargeable battery NI-MH
Powering: 220 V - 50 Hz
Autonomy: 10 h
Recharge Time: about 15 h.
Weight: kg 2
Size: 120 x 145 x 50 mm + base
RS-232 INTERFACE for PC connection

LE 301 : ELECTRONIC LEVEL WITH DEFERRED MEASURE

The new LE 301 electronic level completes our range of precision instruments for linearity and flatness measurements. Here its main characteristics are listed: MEASURING SYSTEM OPERATING THROUGH MENUS; LINEARITY AND FLATNESS MEASUREMENTS; SELECTABLE UNIT OF MEASURE: $\mu\text{m}/\text{m}$, sec, μrad ; STORAGE OF INPUT DATA FOR DEFERRED TRANSMISSION TO PC; RS-232 INTERFACE; PC-RESIDENT SOFTWARE UNDER WINDOWS; DIFFERENTIAL MODE MEASUREMENTS (WITH TWO LEVELS). This electronic system is based on a high performance microprocessor that drives the A-D converter of a very sensitive LVDT (Linear Variable Differential Transformer). Sensitivity as high as 0.5 micron/meter (0.1 seconds of arc). The instrument's internal software guides the operator with a easy menu-based interface, implemented on a 16-character alphanumeric display and a 6-key simplified keyboard, through which commands are entered. A remote control is a valid aid for simple commands and functions. The serial RS 232 link allows data stored in the instrument to be transferred to a PC for either on-line or off-line processing. In the PC, a program running under Windows treats data to yield a complete representation of the measured object, offering also the possibility to produce hardcopies of both numeric and graphic outputs.

Supplied in ABS box with user's guide.

Resolution: 0.1 sec / $1\mu\text{rad}$ / 0.0005 mm/m
Field of Measure: 655 sec
Reaction Time: 3 sec tipico
Straightness: $\pm 2\%$
Reference Temperature: 20°C - 50% U.R.
Alimentation: NI-MH rechargeable batteries
Autonomy: 10 h (time-switch-off)
Recharge time: about 15 h (battery test)
Weight: Base 200: 2 Kg / Squared Base: Kg 4
Size: 120 x 145 x 50 mm
Powering of Battery Charger: 220 V a.c. 50 Hz.
Internal Software: 3 main menu
Remote control for the main functions
RS-232 INTERFACE for PC connection



LE0412	ELECTRONIC LEVEL MOD. LE101	BASE mm 100 / 200
LE0420	ELECTRONIC LEVEL MOD. LE101	SQUARED BASE
LE0440	VA110 - READ-OUT UNIT	For LE101
LE0438	RS-232 SERIAL INTERFACE	(Optional for Le101)
LE0425	ELECTRONIC LEVEL MOD. LE201	BASE mm 100 / 200
LE0426	ELECTRONIC LEVEL MOD. LE201	SQUARED BASE
LE0445	ELECTRONIC LEVEL MOD. LE301	BASE mm 100 / 200
LE0446	ELECTRONIC LEVEL MOD. LE301	SQUARED BASE
LE0435	LEVEL/PC CONNECTION CABLE	For LE 201 and 301
LE0437	BATTERY CHARGER	For LE101-201-301
LE0439	W-PLAN FLATNESS SOFTWARE	(For WINDOWS)

LE 051: DIGITAL AND ANALOGUE ELECTRONIC LEVEL

The electronic level is composed by a stabilized cast iron structure with two right-angled sides, useful for testing the perpendicularity; two incorporated displays, one **analogue** and one **digital**; a **wooden handle** (in order to prevent influences on the structure with the manual contact); the inner mechanic of the pendulum is in an **oil-bath** box which protects against accidental shocks. A commutator permits the selection of **one of the five possible resolutions**, while a potentiometer permits the adjustment of the "zero". Rechargeable battery-powered, has a button which indicates the state of battery charge.

Resolution : A: 250 $\mu\text{m}/\text{m}$ / B: 50 $\mu\text{m}/\text{m}$ / C: 10 $\mu\text{m}/\text{m}$ / D: 5 $\mu\text{m}/\text{m}$ / E: 1 $\mu\text{m}/\text{m}$ for division
Field of measure: A: 5000 $\mu\text{m}/\text{m}$ / B: 1000 $\mu\text{m}/\text{m}$ / C: 200 $\mu\text{m}/\text{m}$ / D: 100 $\mu\text{m}/\text{m}$ / E: 20 $\mu\text{m}/\text{m}$
Reaction time: 3 sec tipico
Straightness: $\pm 2\%$
Alimentation : Rechargeable battery
Level Weight : Kg. 4,4
Powering: 220 V a.c. 20 mA.
Zero Setting: $\pm 1500 \mu\text{m}/\text{m}$
Reference temperature: 20°C - 50% U.R.
Autonomy: 100 h - normal use
Size: 220 x 220 x 50 mm
Packing: ABS valise + box



LE 401: RADIO TRANSMISSION ELECTRONIC LEVEL

The evolution of the electronic level has been concentrated in this new instrument, LE401 where inclination values are transmitted through a **radio connection**. The instrument is composed by: a **digital readout** unit (VD410), and a **pendulum unit** (LE401). The pendulum unit, as for the other models of electronic level provided by Microplan Group, uses the oil-bath system for shock damping, while the digital read-out unit is used for the transmission/reception of data from the sensible unit, without any cable. In the same unit, the ON/OFF button, the PC and battery charger connection and a command keyboard are located. The two units can communicate with a maximum distance of 100 m: the VD410 unit can read the signals from 1 up to 10 pendulum units at the same time. The digital and graphic display gives you the exact value of inclination, along with the inclination direction; a complete range of values can be stocked by the VD410 unit and can be then transmitted to the PC through an apposite connection cable and **WPLAN** ©MICROPLAN Software: the data elaboration follows 4 different methods: 1) Straightness; 2) Easy-grid flatness; 3) Complete-grid flatness; 4) Parallelism. The operator can also select or change the following parameters: Measure Unit ($\mu\text{m}/\text{m}$; arc seconds; microrad); Zero Setting (Absolute or easy); Time-out.

Resolution is 0,5 $\mu\text{m}/\text{m}$. Rechargeable batteries with status indication. The complete instrument is provided in ABS valise with accessories, battery charger, user's guide and WPLAN©Microplan Software on CD-R.
Packing: box



LE 0439 - WPLAN FLATNESS SOFTWARE

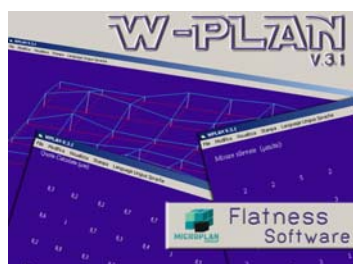

The WPLAN©Microplan Software allows the elaboration of flatness and straightness measures found with the electronic levels, models, LE 101, LE201, LE301 and LE401, in way to find the elevations and the graphic view of the plates or measured surfaces. The new release works with Windows operating systems 95/98/ME, 2000/NT/XP in four languages (Italian, French, English and German). The **free Demo Version** is available on the website www.microplan-group.com. This Software comes supplied on **CD-R**, with **User's guide** and **Hardware Protection Key**.

HIGH PRECISION SPIRIT LEVELS

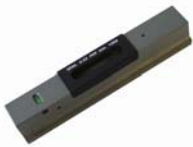

High precision rectangular level for flatness and cylindrical surface testing. Supplied with a wooden box.

LB	0450	Linear Spirit Level mm 200	mm/m 0,02
LB	0451	Linear Spirit Level mm 250	mm/m 0,02
LB	0452	Linear Spirit Level mm 300	mm/m 0,02

Precision square level with two plane faces and two prismatic bases for surface plates and cylinders testing either horizontal or vertical. One longitudinal big spirit-level and a little transversal one. Insulating handle. Supplied with wooden box.



LB	0453	Squared Spirit Level mm150	mm/m 0,02
LB	0454	Squared Spirit Level mm200	mm/m 0,02
LB	0455	Squared Spirit Level mm250	mm/m 0,02

FLATNESS TOLERANCE : $\pm (0.001 + L/250.000)$ mm

PERPENDICULAR TOLERANCE : $\pm (0.002 + L/100.000)$ mm

TESTING AND OVERHAUL

Overhaul is giving again the **original tolerance of flatness to a surface plate**. This is realized on any kind and any size of plate and may be done **by your workshop** on request. If you ask for manufacturing or drilling operation, we call this repair, quite different than renovation (possible only by our workshop). Coming to the customer's workshop, all necessary tools are provided by our firm, while it is necessary to get water and electrical power (220 V- 50Hz) just near the intervention place. With each surface plate renovated, **Microplan** releases a **Original Test Report**, where are indicated: size, tolerances and serial number of the plate, the characteristics of the environment when testing, the reference to **Certificated Primary Instruments**, all values recorded and transformed through the software to a theoretical plan., the total and closing error, the position of fulcrum points during the testing.

For any overhaul or special enquiry, do not hesitate to contact our sales office.

SPECIAL WORKINGS ON DRAWING

Microplan Group provides **special granite bases according to the specific needs and drawing of the Customer**: machine tools bases, measure machine, for microelectronics, electro-erosion machines, printed circuit drilling machines, test bench, research centers, etc... The maximum size of worked bases is **10.000 mm length, 3.000 mm width**. For big sizes we usually use Blue Lanhelin granite.

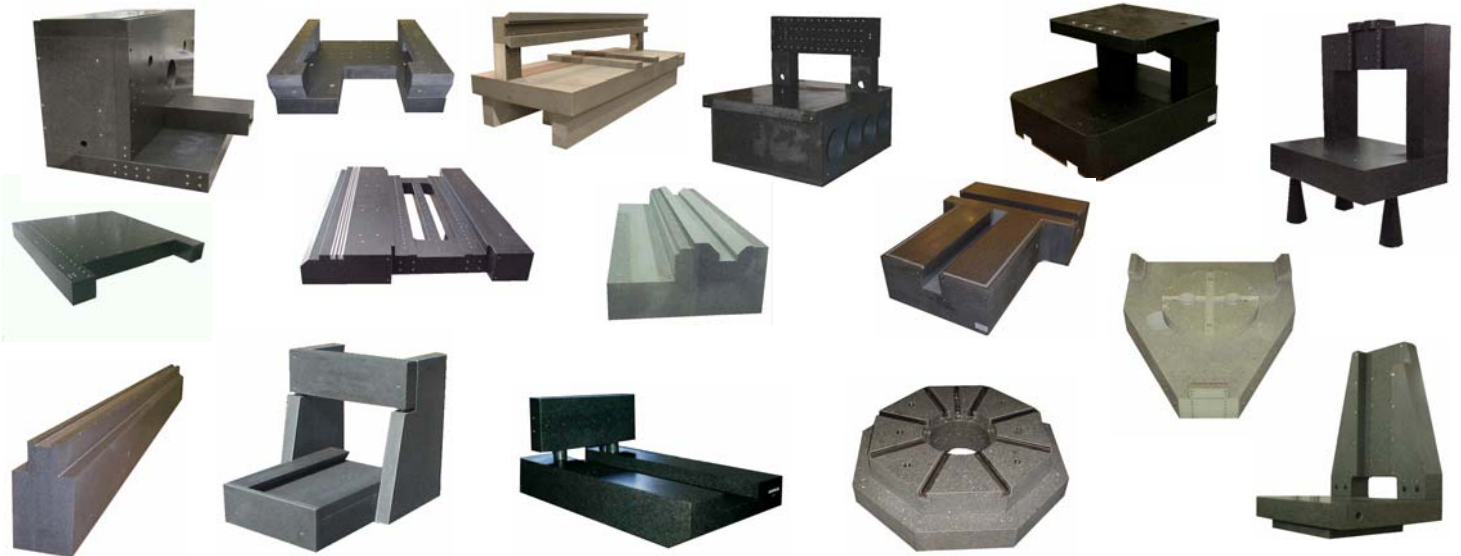

INNOVATIVE SOLUTIONS FOR MEASURE AND TESTING

The standard measuring instruments normally used are not always the best solution for **metrological testing** of some mechanical parts. There are many possible causes: the minimum requested time for checking, the exorbitant cost running on some tools, the place where the test is run (workshop instead of laboratory), the specificity relating to the parts to be tested, the difficulty of use and the training required to use complex tools, the staff know-how, etc. In these cases the **ideal solution** would be the use of a tool that **has been specially developed to test a specific part**. The appliances shown in "Customer's Solutions" documentation are only examples of what Microplan Group has realized in this particular field. Our know-how regarding the **metrological field** and in particular the production of **precision mechanics** (slideways, composite and innovative materials) and **electronics and software development** have enable us to solve several "measurement" problems, thanks to a modular-planning system and to the integration of products such as measurement scales, laser systems, linear motors, etc. Often the project for a special instrument is born thanks to **co-operation with the customer**, who knows his production and what he wants to obtain from a specific measurement tool. Often the consequence of these co-operations, besides the **purchaser's technical satisfaction**, means an outstanding saving compared to the budget forecasts, to such an extent that after the first production further quantities are requested. The technologies applied to metrology are sometimes also used in order to develop machines, where precision is the main requirement and where the results are achieved through non-traditional processes. The present day Microplan Group offers valuable know-how to all the Companies interested in **solving specific "measurement" problems**, using technologically advanced, innovative and economically interesting solutions.

"*Custom's Solutions*" documentation is now available in PDF file on our website www.microplan-group.com, in the download section.

